



Colour
anthracite

Certifications

- CE certified
- IAB certified



Certificate no. 05/0227

Permo[®] frame is a single-layer, vapour permeable membrane for use on timber framed walls and behind vertical cladding.

Product features & benefits

- Strong vapour permeable timber frame wall membrane
- 1.5m, 2.7m and 3m widths
- UV stable for 4 months
- Allows the wall structure to breathe
- Windtight and draught-free
- Highly vapour permeable with no risk of condensation build up
- Can be used with any cladding
- Protects timber and insulation during construction
- Can be fixed directly to insulation or sheathing with no 'tent' effect
- Reduce energy loss by using in conjunction with Klobér's range of airtightness products
- Protects the ply or OSB sheathing and the timber frame from external moisture ingress, yet allows the wall structure to breathe
- Resistant to the passage of water and wind-blown dust and snow

Area of application

Suitable for use on:

- Timber framed walls
- Steel-framed walls
- Factory pre-assembled panels
- On-site assembled frames
- Suspended timber ground floors to support the insulation

Material

A strong non woven spun bonded polypropylene sheet material. It exceeds the requirements for a material as defined in BS4016: 1997.

Roll sizes / weights

1.5 x 50m	75 m ²	7.5kg
2.7 x 100m	270 m ²	27kg
3.0 x 100m	300m ²	30kg

TECHNICAL DATA

Weight EN 1849-2	100g/m ²	
Water vapour transmission EN 12572 (sd value)	0.02MNs/g	
Water column	W2	
Tensile strength longitudinal/transverse EN 12311-1	255N/50mm	200N/50mm
Elongation longitudinal/transverse EN 12311-1	50%	50%
Resistance to tearing (nail shank) longitudinal/transverse EN 12310-1	130N	130N
Reaction to fire EN 13501-1, EN 11925-2	F	
Resistance to temperature	-40°C	
UV exposure*	4 months	
Product code	KU0059-3-1-15-10 (1.5 x 50m)	
	KU0059-3-1-27-10 (2.7 x 100m)	
	KU0059-3-1-30-10 (3.0 x 100m)	

*The Underlay can be used to provide temporary weather protection; however an exposed underlay will be subjected to UV light which may lead to premature failure; therefore, the exposure period should be kept to a minimum. An underlay is not a total waterproof barrier and if used as a temporary waterproof covering, some rain penetration may occur. In certain conditions, particularly if there is persistent heavy rainfall combined with subsequent severe freeze/thaw conditions, an underlay should not be exposed for more than a few days. (BBA)

Klobér Ltd

Unit 6F · East Midlands Distribution Centre · Short Lane · Castle Donington · Derbyshire · DE74 2HA
Tel. +44 (0)1332 813 050 · Fax +44 (0)1332 814 033 · info@klober.co.uk · www.klober.co.uk

KLOBÉR

Typical timber frame wall construction

Timber battens to form a services void and avoid service penetrations through the vapour control layer

Wallint[®] 50 air barrier/vapour control layer

Water resistant Permo[®] frame repels any wind-driven water that penetrates the outer cladding

Water vapour passes through Permo[®] frame to the vented cavity

Moisture is dispersed from the vented cavity

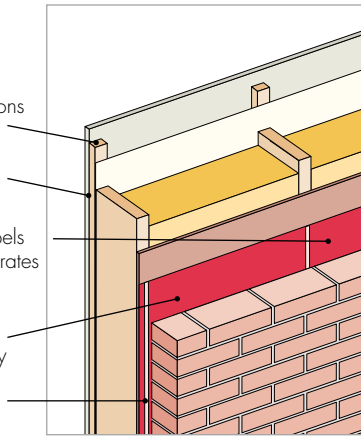

Typical timber ground floor construction

Insulation between floor joists

Permo[®] frame stapled to side of joist to depth of insulation

Permo[®] frame supports insulation between joists

Moisture is dispersed from the vented sub floor space

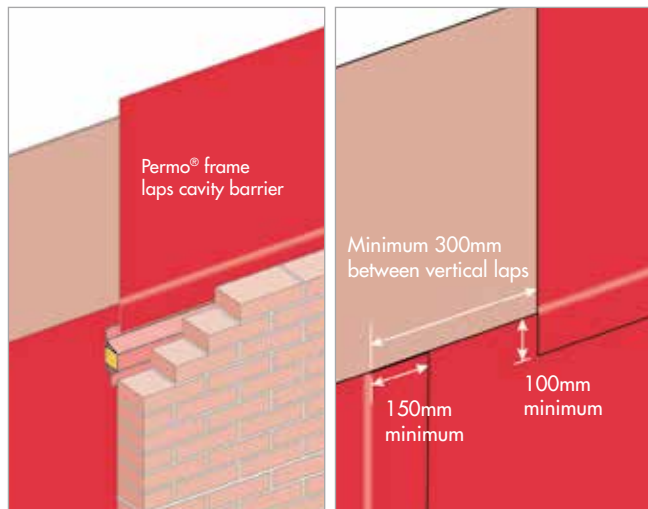
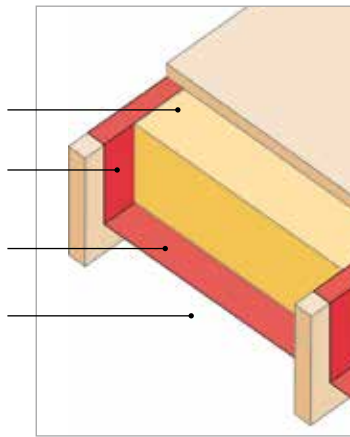

Typical details

Turn Wallint[®] 50 or solar air barrier/vapour control layer into reveals

Permo[®] frame turned into openings

Cavity closer with flashing

Permo[®] frame turned into openings and lapped by Wallint[®] 50 or solar air barrier/vapour control layer

Cavity closer with flashing

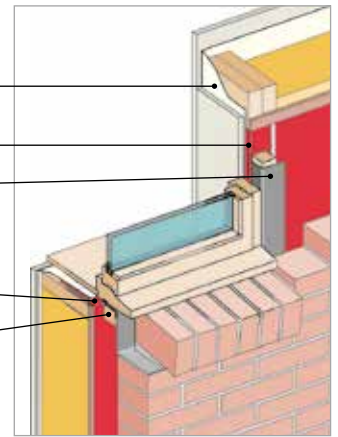

Cladding options

Treated timber battens nailed to studs

Cedar shi lap boarding

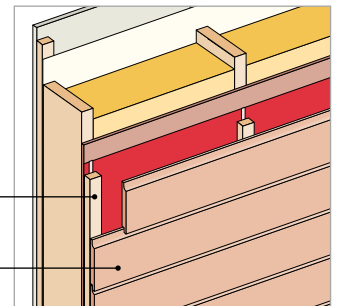

Treated timber battens gauged to suit tile size

Clay or concrete plain tiles

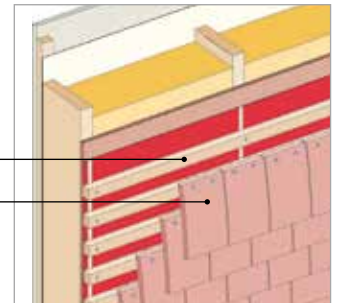

Note: Klobber recommend that 19mm deep counter battens are used on sites that are severely exposed.

Installation

Permo[®] frame should be laid in accordance with our installation details.

Permo[®] frame provides a complete barrier to moisture and must be installed to channel water to the outside. The upper layers must overlap the lower layers and also lap and cavity trays. Unroll Permo[®] frame horizontally and fix to the outside of the frame. Ensure the membrane covers the lowest frame member by a minimum of 25mm. At external corners return the membrane at least 300mm. Form 100mm horizontal laps and 300mm vertical laps. Stagger vertical laps by a minimum of 300mm. Optionally, tape and seal laps with either Permo[®] TR plus or Tacto[®] adhesive tape.

All tears and rips within the Permo[®] frame must be repaired using Permo[®] TR plus tape. Nail or staple Permo[®] frame, using non corrosive fixings, to every stud at maximum 300mm centres. At window openings turn the Permo[®] frame into the opening, fix to the reveals and trim. Tape to create an air & windtight seal.

Permo[®] frame is strong and durable in normal use, but should not be exposed to sunlight for more than four months. On very exposed sites and tall buildings, or if cladding may be delayed, Klobber recommend that any battening is fixed immediately, with edge battens fixed all round the perimeter to help prevent lifting and damaging of the membrane in extreme conditions.

TS-09#22-UK-0317. We assume no liability for typing errors.

Klobber Ltd

Unit 6F · East Midlands Distribution Centre · Short Lane · Castle Donington · Derbyshire · DE74 2HA
Tel. +44 (0)1332 813 050 · Fax +44 (0)1332 814 033 · info@klobber.co.uk · www.klobber.co.uk